

**2023 Hi-Tec Oils Bathurst 6 Hour**  
**Mount Panorama, Bathurst New South Wales**  
**7 – 9 April 2023**  
**Supplementary Regulations**

**Motorsport Australia Permit Number**  
**823/0904/01**



# INDEX

INDEX.....	2
1. GENERAL.....	3
2. SPORTING.....	7
3. BRIEFINGS, SCRUTINEERING, CHECKING.....	12
4. PRACTICE, QUALIFYING, RACE, REPAIRS.....	14
5. FUEL, TYRES.....	23
6. BALANCE OF PERFORMANCE.....	24
7. ADDITIONAL INFORMATION.....	25
8. AUTOMOBILE MARKINGS.....	26
Attachment A.....	28
Attachment B.....	36
Attachment C.....	37
Attachment D.....	38

# 1. GENERAL

## 1.1. Event Title, Date and Venue

- 1.1.1. Hi-Tec Oils Bathurst 6 Hour
- 1.1.2. April 7 to April 9 2023
- 1.1.3. Mount Panorama, Bathurst, New South Wales

## 1.2. Organisation and Status

- 1.2.1. The Event is to be held under the FIA International Sporting Code including Appendices, the National Competition Rules (NCR) of Motorsport Australia, the Circuit Race Standing Regulations (CRSR) published by Motorsport Australia, Motorsport Australia Motor Sport Passenger Ride Activity Policy (MSPRA), these Supplementary Regulations and any Further Supplementary Regulations and Bulletins to Competitors that may be issued, and any instruction issued by the Clerk of the Course.
- 1.2.2. The Event will be conducted under and in accordance with Motorsport Australia OH&S, Safety 1st, Integrity and Legal, and Risk Management Policies, which can be found on the Motorsport Australia website at [www.motorsport.org.au](http://www.motorsport.org.au).
- 1.2.3. Status – The Bathurst 6 Hour Competition will be National.

## 1.3. Administration and Event Staff

- 1.3.1. ASN: Motorsport Australia  
Box 172, Canterbury LPO, Victoria, 3126  
T: +61 (0)3 9593 7777 E: [info@motorsport.org.au](mailto:info@motorsport.org.au)
- 1.3.2. Promoter and Organiser:  
Australian Racing Group (ARG)  
Level 3, 5 Rider Boulevard, Rhodes NSW 2138  
E: [events@australianracinggroup.com](mailto:events@australianracinggroup.com)  
W: [www.bathurst6hour.com.au](http://www.bathurst6hour.com.au)
- 1.3.3. Organising Committee:  
Ken Collier, Mark Rayner, David Mori, Lawrie Schmitt, Christopher Gough, Kimberly Hughes.
- 1.3.4. Organiser Rights:  
The Organiser retains the right to postpone, abandon or cancel the Event in accordance with the NCR.

## 1.4. Officials

Stewards:	TBA
Clerk of the Course:	David Mori
Secretary of the Event:	Kimberly Hughes
Bathurst 6 Hour Administrator:	Ken Collier
Bathurst 6 Hour Technical Director (TD):	Chris Gough
Bathurst 6 Hour Assistant Technical Director/s (ATD):	TBA
Chief Medical Officer:	TBA
Chief Scrutineer:	TBA
Chief Timekeeper:	TBA
Compliance Checker:	TBA
COVID Checker:	TBA
Judges of Fact:	TBA
Media Manager:	Richard Crail
Paddock Manager:	Graham Sattler

## **1.5. Circuit and Race Details**

- 1.5.1. Length: 6.213 km  
Direction: Anti-clockwise  
Track Density: Bathurst 6 Hour - 72  
Control Line: Located at the Finish Line and pit lane entry  
Race Date: Sunday 9 April 2023  
Race Duration: 6 Hours  
Race Start: 11:15 AEST Sunday 9 April
- 1.5.2. Official Notice Board: The Official Notice Board will be located at the base of Tower 3.

## **1.6. Event Schedule**

The Event Schedule will be published in the Further Supplementary Regulations

## **1.7. Entries & Fees:**

- Entry Opening date: Upon publication of these Regulations
- Entry Closing date: 10 March 2023
- 1.7.1. Competitors are responsible for sending correct and complete entries on the Official Entry Form and paying the correct entry fee prior to the entry closing date. An entry will only be accepted based on full payment of the entry fee.
- 1.7.2. All entries must be sent to:  
ARG Events  
Email: [events@australianracinggroup.com](mailto:events@australianracinggroup.com)  
Post: ARG Events – Bathurst 6 Hour  
Level 3, 5 Rider Boulevard  
Rhodes, NSW 2138
- 1.7.3. All incorrect or incomplete entries that have paid the entry fee (including entries with Driver TBA) will be deemed as suspended until they are complete and correct. This is the responsibility of the Competitor and must be finalised within the terms of the Invoice and no later than 10 March 2023. All Driver and Automobile information will be checked and verified by the Secretary of the Event immediately after the Entry Closing Date.
- 1.7.4. If full grid capacity is reached prior to the Entry Closing Date, the Bathurst 6 Hour Administrator reserves the right to accept those valid entries which it deems most suitable.
- 1.7.5. Entry Fees – All Classes:
  - 1.7.5.1. For Competitors who submit a complete entry form and pay in full by 2 December 2022, the entry fee will be \$7,150 including GST. This includes a discount of \$2,420 including GST on the full entry fee.
  - 1.7.5.2. For Competitors who submit a complete entry form and pay in full after 2 December 2022 and before 10 March 2023, the entry fee will be \$9,570 including GST.
- 1.7.6. Entries and Payment:
  - 1.7.6.1. Fee Payment can be made by Electronic Funds Transfer (EFT) or Credit Card as per the details on the entry form.
  - 1.7.6.2. All EFT payments must include a payment reference noting the Competitors Reference Number (CRN) as issued by the Organiser. If a Competitor is unaware of their CRN they must contact the Organiser to confirm. The payment confirmation slip must be emailed to the Organiser: [events@australianracinggroup.com](mailto:events@australianracinggroup.com)
- 1.7.7. The Organiser reserves the right to accept or refuse a valid entry at their sole discretion in accordance with the NCR.

## **1.8. Refund of Entry Fee**

The entry fee may be refunded under the following conditions:

- 1.8.1. Refusal of an entry: Full refund of all payment received.
- 1.8.2. Withdrawal of an entry up until 17 February 2023: Full refund of all payment received.
- 1.8.3. Withdrawal of an entry after 17 February 2023 and before 17 March 2023: Refund of all payment received less a cancellation fee of \$2,200 including GST.

1.8.4. Withdrawal of an entry after 17 March 2023: No refund.

### 1.9. Organiser's Rights

1.9.1. The Organiser reserves the right to cancel any Class which has less than 3 Automobiles entered or amalgamate them to the next higher Class at their discretion.

1.9.2. The allocation of each competition number for each Automobile is the sole responsibility of the Bathurst 6 Hour Administrator. A maximum of 3 digit numbers is permitted.

### 1.10. Accreditation

1.10.1. The Accreditation Centre is adjacent to the public entrance gate in Harris Park general access parking area.

1.10.2. The Accreditation Centre opening times are as follows:

Wednesday 5 April, Thursday 6 April 0900hrs – 1700hrs

Friday 7 April, Saturday 8 April 0600hrs – 1700hrs

Sunday 9 April 0600hrs – 1200hrs

1.10.3. Each Automobile entered and paid will be provided with:

1.10.3.1. 12 x Competitor admit one wristband passes (3 Driver passes and 9 pit crew passes).

Competitors can leave passes at the accreditation centre for collection. Passes must be in a standard DL envelope with the Automobile's competition number and name of the person collecting written on front.

1.10.3.2. 2 Outer Paddock vehicle passes for access to the Competitors Car Park.

1.10.3.3. Upon request at the Event Office (Level 1 near Tower 1) the Organiser may issue a Paddock Transit Pass for temporary vehicle access to the Inner Paddock area for the purpose of equipment unloading. All Paddock Transit Passes issued must be returned to the Event Office immediately after use. **Note - Parking is strictly prohibited in the Inner Paddock. All vehicles must be parked in the Competitors Car Park in the area provided near the paddock campground area.**

1.10.4. Each Competitor and crew must always wear their pass when in the venue.

1.10.5. It is each Competitor's responsibility to make sure their team and crew members have signed any and all Event and Motorsport Australia forms prior to administration document checking.

1.10.6. All vehicle passes, except for any temporarily issued Inner Paddock Transit Pass, must be fixed (adhered) to the front windscreen in the top right (Driver) side corner.

1.10.7. Team transporters do not require vehicle passes.

### 1.11. Paddock Access

1.11.1. Access to the paddock area will be available from 08:00 on Wednesday 5 April.

All vehicles must proceed along the pit straight and into the Paddock area via the Mountain Straight gate or as directed by Event staff.

All team transporters and trailers should be at the track no later than 17:00 on Wednesday 5 April. All teams must follow set-up and other directions as supplied or given by the Bathurst 6 Hour Administrator, the Paddock Manager or their nominee's.

1.11.2. Bump In – Wednesday 5 April

All team members involved in bump in must be aware of and comply with all NSW Workplace Health and Safety requirements including the wearing of high visibility vests.

Teams must collect their garage keys (2 per garage) from the Event Administration Office and pay a \$100 **cash** deposit. Where a garage is being shared, the person collecting the keys is responsible for the return of both.

1.11.3. Bump Out – Sunday 9 April (post-race)

The bump out of the Pit Lane Garages must be completed by 20:00 on Sunday evening. All garage keys must be returned by this time and failure to do so will result in the forfeit of the key deposit paid during bump in.

All team members involved in bump out must be aware of and comply with all NSW Workplace Health and Safety requirements including the wearing of high visibility vests.

1.11.4. Truck tail gates when on the ground must have each corner marked with a high visibility safety cone. A spotter must be present when tail gates are being lowered, raised or off the ground to warn others against walking/driving under the tail gate. Tail gates must always be in the closed

position when not in use for loading and unloading.

- 1.11.5. Transporters will be free to depart from the Paddock in a safe manner at any time after the Mountain Straight gate is opened at the completion of track activities each day.
- 1.11.6. During all track closure periods, access to the Paddock area for vehicles and occupants with approved passes is via the Chase tunnel access road. Note - the Chase tunnel is 3.1 metres high and 2.7 metres wide.

**1.12. Alcohol, Drugs and Other Substances:**

- 1.12.1. Any holder of a Motorsport Australia Licence (or a Licence issued by another ASN) may be tested for the presence of any drug or other banned substance and subject to a penalty for a breach of the Australian National Anti-Doping Policy and/or the Motorsport Australia Illicit Drugs in Sport (Safety Testing) Policy at [www.motorsport.org.au](http://www.motorsport.org.au).
- 1.12.2. The consumption of alcohol is prohibited at all times in the pit lane and/or pit lane garage including after the end of Competition for the day. Consumption of alcohol in the paddock or any other Reserved Area is prohibited until all Competition is concluded each day. The holder of a Motorsport Australia Licence (or a Licence issued by another ASN) may be tested for the presence of alcohol by a Motorsport Australia Accredited Testing Official (CATO) in accordance with the Motorsport Australia Alcohol Policy at [www.motorsport.org.au](http://www.motorsport.org.au).
- 1.12.3. When permitted, alcohol can be consumed from cans in the Inner Paddock Area, GLASS BOTTLES are strictly prohibited.

**1.13. Medical Centre Hours of Operation:**

- 1.13.1 The Medical Centre will be open at the following times.  
Friday 7 April to Sunday 9 April – 07:00 to 18:00.
- 1.13.2 If you require medical assistance outside the open hours, please call “000” and provide the operator with your exact location details:  
Mount Panorama Motor Race Circuit  
Panorama Avenue Bathurst, NSW  
And your specific location, example Pit Lane Garage XX

**1.14. Industrial Gas Supply:**

- 1.14.1. Competitors are free to use any brand of Industrial Gas.
- 1.14.2. Competitors are responsible for the removal of all gas bottles prior to leaving the circuit when they are finished at the Event.

**1.15. General Safety**

- 1.15.1 The Mount Panorama Circuit is a public road which is closed for competition periods. At all non-competition times during the Event, access is restricted and limited to authorised personnel and vehicles only, which must respect and obey all relevant road rules.

## 2. SPORTING

### 2.1. Competitor and Driver Licence Requirement

- 2.1.1. Each Competitor must hold a Motorsport Australia Competition Licence,  
*or*  
hold a Motor Sport New Zealand competition licence and Tasman Visa valid for the Event.  
*or*  
hold a minimum of the highest grade National Licence issued by a Foreign ASN together with an authorisation issued by that ASN for the Event. These Competitors must apply to Motorsport Australia for a Foreign Participation Visa (FPV) authorisation to compete at least 10 days prior to the Event.
- 2.1.2. Each Driver must hold a minimum of a Motorsport Australia Circuit Licence without a provisional endorsement,  
*or*  
hold a Motor Sport New Zealand competition licence and Tasman Visa valid for the Event,  
*or*  
hold a minimum of the highest grade National Licence issued by a Foreign ASN together with an authorisation issued by that ASN for the Event. These Drivers must apply to Motorsport Australia for a Foreign Participation Visa (FPV) authorisation to compete at least 10 days prior to the Event.

### 2.2. Team Manager

- 2.2.1. Each Competitor must nominate a Team Manager to the Bathurst 6 Hour Administrator by 10 March 2023. The nomination must include the Team Manager's name, mobile phone number and email address.
- 2.2.2. The nominated Team Manager cannot be a Driver entered for any Automobile in the Bathurst 6 Hour competition.

### 2.3. Administration Checking

- 2.3.1. Date, Time, Location:
- 2.3.1.1. Wednesday 5 April from 10:00 to 13:00 and 14:00 to 16:00 at Suite 11, Level 1 near Tower 3.
- 2.3.1.2. Thursday 6 April from 10:00 to 13:00, at Suite 11, Level 1 near Tower 3.
- 2.3.1.3. Administration checking outside these hours will be at the discretion of the Secretary of the Event.
- 2.3.2. Administration checking must be conducted prior to the Automobile being presented for scrutineering.
- 2.3.3. Competition licences will be validated prior to the event, however, all Competitors and Drivers should ensure that their Licence and passbook is available upon request.
- 2.3.4. Automobile logbooks must be given to the Secretary of the Event or their nominee during the administration checking times specified above.
- 2.3.5. Each team manager must email the following documents to the Bathurst 6 Hour Administrator [administrator@bathurst6hour.com.au](mailto:administrator@bathurst6hour.com.au) prior to 24 March 2023:
- 2.3.5.1. Scanned copies/photographs of each Competitor/Drivers Motorsport Australia affiliated Car Club Membership Card (for licences issued by Motorsport Australia only)
- 2.3.5.2. For all New Zealand Competitors/Drivers, a scanned copy of each Competitor and Driver Licence, and a valid Tasman Visa
- 2.3.5.3. For all International Competitors/Drivers, a scanned copy of each Competitor and Driver Licence, and the relevant Australia Foreign Participation Visa Form for both a Competitor and/or Driver Licence.
- 2.3.5.4. Scanned completed Motorsport Australia Self-Scrutiny Checklist and Statement of Vehicle Compliance.
- 2.3.6. Each Competitor must ensure that the Motorsport Australia Risk Warning and Disclaimer form has been completed by each of their team members and submitted to the Secretary of the Event prior to their Automobile participating in its first track session.  
Motorsport Australia will not cover any team member whose signature does not appear on the

disclaimer for insurance purposes.

## **2.4. Eligible Automobiles**

- 2.4.1. Bathurst 6 Hour Classes X, A1, A2, B1, B2, C, D, E are eligible to enter. Each eligible Automobile is shown on the List of Eligible Automobiles in Attachment A. Each eligible Automobile must comply with Motorsport Australia Group 3E - Series Production Car Regulations, as published in the Motorsport Australia Manual.
- 2.4.2. Unless agreed otherwise by the Organiser and approved by the Stewards, only the original Automobile presented for scrutineering may be used during the Event. Replacement Automobiles are prohibited.

## **2.5. Paddock Allocation, Transporter and Trailer Parking**

- 2.5.1. The Bathurst 6 Hour Administrator will allocate a maximum 4m x 25m area in the Inner Paddock for the sole purpose of parking of team transporters. Individual requests will be considered however there is no right to be allocated a specific area.  
The Inner Paddock is a shared zone between entrants of the Bathurst 6 Hour and support categories as nominated by the Organiser.  
The area is to be used only for team transporters or containers. No area in the Inner Paddock can be fenced, barriered, roped, marked or include any structure at any time without the express permission of the Organiser or Paddock Manager.  
No road vehicles can be parked in the Paddock and any unauthorised vehicles found in the Paddock may be towed at the owner's expense.  
Small trailers must be parked in the designated trailer parking zone as advised by the Organiser. These trailers can be unloaded in the Paddock prior to parking in the designated area.
- 2.5.2. Paddock gates 1 and 2 will be secured each evening commencing from Wednesday 5 April and at other times from Thursday 6 to Sunday 9 April. Security will be based at Gate 3 to control the access and exit of the paddock. Teams are responsible for the security of their own vehicles and equipment.
- 2.5.3. Camping is only permitted in the designated campgrounds. All camping must be booked through the Bathurst Regional Council and details of contacts will be supplied by the Organiser.

## **2.6. Paddock Area**

- 2.6.1. NO SMOKING areas apply throughout the venue including the pit lane, pit lane garages and paddock area. The use of e-cigarettes and misters is also prohibited in these areas.
- 2.6.2. The following speed limits apply in the Paddock Area at all times:
  - 2.6.2.1. Inner Paddock – 10 km/h
  - 2.6.2.2. Outer Paddock – 20 km/h
  - 2.6.2.3. Camping Areas – 20 km/h
- 2.6.3. Motorised Vehicles:
  - 2.6.3.1. 2-wheeled motorised vehicles are prohibited in any area of the venue.
  - 2.6.3.2. Unregistered 4-wheeled vehicles are prohibited in any area of the venue.
  - 2.6.3.3. Registered 4-wheeled motorised vehicles are permitted in all paddock areas. Registration plates must be on the vehicle in accordance with NSW State Legislation at the Event at all times.
  - 2.6.3.4. Golf Car Vehicles must have "Conditional" registration plates fitted.  
Competitors who intend using a Golf Car at the Event must first obtain permission from the Bathurst 6 Hour Administrator. A copy of the registration certificate and an insurance certificate must be submitted to the Bathurst 6 Hour Administrator prior to the Event.  
The Bathurst 6 Hour Administrator will issue a compliance form that must be displayed on the vehicle.
- 2.6.4. It is prohibited to wash any truck, transporter, trailer, or vehicle in the paddock area. Any breach of this rule will be referred to the Stewards.

## **2.7. Race Control Electronic Communications**

- 2.7.1. Each Automobile will be allocated a unique email address prior to the Event.
- 2.7.2. Each team must have a personal computer to use in the garage. Connection to the race system requires an Ethernet patch lead which can be plugged into the ADSL socket in the garages.
- 2.7.3. Each computer must have current and operating anti-virus and spyware / malware software installed.
- 2.7.4. All Team Managers must reply to the test email to the Secretary of the Event on Thursday 6 April – [secretary@bathurst6hour.com.au](mailto:secretary@bathurst6hour.com.au)
- 2.7.5. Each team must allocate a crew member to monitor the race control email system prior to, during and after each track session.
- 2.7.6. The following email addresses will be used prior to and during the Event:

Bathurst 6 Hour Administrator -	<a href="mailto:administrator@bathurst6hour.com.au">administrator@bathurst6hour.com.au</a>
Secretary of the Event -	<a href="mailto:secretary@bathurst6hour.com.au">secretary@bathurst6hour.com.au</a>
Technical Director -	<a href="mailto:tech@bathurst6hour.com.au">tech@bathurst6hour.com.au</a>
Media Manager -	<a href="mailto:media@bathurst6hour.com.au">media@bathurst6hour.com.au</a>
IT Manager -	<a href="mailto:it@bathurst6hour.com.au">it@bathurst6hour.com.au</a>

Additional email addresses being used during the Event only:

Clerk of the Course -	<a href="mailto:race-control@bathurst6hour.com.au">race-control@bathurst6hour.com.au</a>
Timing -	<a href="mailto:timing@bathurst6hour.com.au">timing@bathurst6hour.com.au</a>

## **2.8. Race Team Radio Communication**

- 2.8.1. Two-way radio communication is mandatory between Driver and pit crew.
- 2.8.2. Each Competitor must advise the Bathurst 6 Hour Administrator of their radio frequency via the Two-way Communication Form (Attachment B) by 10 March 2023.
- 2.8.3. All frequencies will be checked for compliance with the Australian Authorities. If radio frequencies conflict with the host Circuit or emergency frequencies, Competitors will be compelled to change their frequency.
- 2.8.4. Radio and Frequency licensing and permits are the responsibility of each individual Competitor.

## **2.9. Race Management Channel (RMC)**

- 2.9.1. Each team MUST monitor the RMC on “listen only” for each track session from 10 minutes before the Automobiles are released from their pit garage to the end of the session.
- 2.9.2. Any message broadcast over the RMC will have regulatory effect.
- 2.9.3. The RMC frequency is **507.3875** MHz with CTCSS of **127.3**:

## **2.10. Timing**

- 2.10.1. The timing hardware system for the Event will be based on the Dorian Transmitter and Driver ID hardware. Each Automobile must be fitted with a Dorian Transmitter and any associated hardware prior to the first track session. Failure to do so may result in the Automobile being black flagged and prohibited from returning to the track until the Driver ID system is fully installed and operational.
- 2.10.2. The timing software for the Event will be Natsoft. Results and live timing will be available through the Bathurst 6 Hour website ([www.bathurst6hour.com.au](http://www.bathurst6hour.com.au)) and Natsoft ([www.natsoft.com.au](http://www.natsoft.com.au)).
- 2.10.3. Driver Identification – Each Automobile must be fitted with a Dorian Micro 16000 DATA-1 Multi-Driver Transmitter.

This is a push button module (see below) which will have four different coloured push buttons, each button is assigned to an individual Driver.

The units are completely self-contained with an internal battery power supply. Each Automobile must have the following components fitted prior to any on track activity:

  - 2.10.3.1. 1 x Dorian Micro 16000 Data-1 Multi Driver Transmitter (see mounting instruction sheet for best placement of this).
  - 2.10.3.2. 1 x Driver ID Control Panel to be mounted in the Automobile where the Driver can press a coloured button when in the Automobile.
  - 2.10.3.3. 1 x wiring loom. This is a 3.6 metre long pre-made cable connecting the transmitter and the control panel. It is recommended that the cable is installed

prior to the Event and each Competitor can purchase a cable (unless already owned) for \$205.50 including GST and postage.



- 2.10.4. Hardware Rental – All hardware can be rented through:  
Timetronics Pty Ltd: Ian Leech or Lucy Hatton.  
Email: timing@timetronics.com.au  
Collection at Circuit: From Thursday 6 April 2023, from timing office.  
Event rental cost of the Dorian transmitter and Driver ID button module is \$121.00 including GST.  
Payment may be made by Cash, Visa Card or Mastercard to Timetronics and will be accepted at the track. Credit card details will be held as security for the units.  
Failure to return the unit at the end of the Event and/or damaged units may result in a charge of up to \$544.50 including GST for the transmitter and/or \$484.00 including GST for the Driver change module and/or \$203.50 including GST for the Cable.
- 2.10.5. Competitors can use their own Dorian system if they have the Multi-Driver Panel system purchased from Timetronics Pty Ltd. If supplied systems are found to not work correctly the Competitor will have to install a working system as detailed above.
- 2.10.6. The Chief Timekeeper will work with all teams to ensure the timing system is working. This could include instructing a team to change a transponder during a pit stop.  
An Automobile may be black flagged to rectify a transponder issue.  
If the Driver ID system is not operational the team can keep the timekeepers updated with Driver changes via the email system (timing@bathurst6hour.com.au).
- At the end of the race while an Automobile is in Parc Ferme, with permission from the Chief Scrutineer, a representative from the team may approach their Automobile under supervision to remove all hired timing equipment and return to the timing representative present. Any Automobile not finishing the race must return all hired timing equipment to the timing room as soon as possible on the day.
- 2.10.7. Telemetry - The use of telemetry is prohibited including live streaming vision and data whilst a session is active.

## 2.11. Driver Requirements

- 2.11.1. Each Driver will be categorised as PRO or AM by the Organiser. Such categorisation will not be subject to protest or appeal.  
Note – a Driver may be categorised as PRO without being a professional, paid driver.
- 2.11.2. Each Automobile must have a minimum of 2 and a maximum of 3 Drivers of which only 1 Driver may be categorised as PRO.
- 2.11.3. Unless the Stewards determine that exceptional circumstances apply, change of Driver nominations will be prohibited after 17:00 on Thursday 6 April 2023.
- 2.11.4. Cross entering of Drivers for the Bathurst 6 Hour Race is prohibited.
- 2.11.5. If an Automobile is withdrawn prior to the commencement of the race as a result of accident damage and/or major mechanical failure during any practice or qualifying session, the Stewards may permit any of the nominated Drivers of the withdrawn Automobile to be listed as an additional Driver in another Automobile, subject to 2.11.2 (i.e., third Driver for a two Driver team).

## **2.12. Driver Qualification Procedure**

- 2.12.1. Driver qualification will be in accordance with the CRSR.
- 2.12.2. Each Practice and Qualifying session will be timed and may count towards Driver qualification.

## **2.13. Driving Time**

- 2.13.1. Driving time will be measured for each Driver from the commencement of the formation lap until the last time the Driver crosses the timing line at the pit lane entry before leaving the Automobile.
- 2.13.2. Subsequently, driving time will be measured for each Driver from the time that Driver first crosses the timing line at pit lane exit when joining the Track through Pit Exit, until the last time the Driver crosses the timing line at pit lane entry before leaving the Automobile or until the Automobile crosses the control (finish) line on the Track at the end of the race.
- 2.13.3. The maximum continuous driving time for each Driver in the race is 3 hours.
- 2.13.4. The penalty for a Driver exceeding the maximum continuous driving time will be as follows:
  - 2.13.4.1. Exceeding time by up to 5 minutes = 1 lap deleted from their Automobile's total number of laps at the end of the race.
  - 2.13.4.2. Exceeding time by more than 5 minutes = 5 laps deleted from their Automobile's total number of laps at the end of the race.
- 2.13.5. A minimum rest period of 1 hour between each driving period for each Driver during the race is required, regardless of the duration of any driving period.
- 2.13.6. The penalty for a Driver not taking the minimum rest period will be 3 laps deleted from their Automobile's total number of laps at the end of the race for every 3 minutes, or part thereof, under 1 hour.
- 2.13.7. The maximum cumulative driving time for each Driver during the race is 3½ hours. The penalty for exceeding the maximum cumulative driving time will be as follows:
  - 2.13.7.1. Exceeding time by up to 5 minutes = 1 lap deleted from their Automobile's total number of laps at the end of the race.
  - 2.13.7.2. Exceeding time by more than 5 minutes = 5 laps deleted from their Automobile's total number of laps at the end of the race.
- 2.13.8. If an Automobile remains stationary for a continuous period exceeding 1 hour in the Automobile's pit lane garage it will be deemed to satisfy the minimum rest period.

## **2.14. Starting Driver Nominations**

- 2.14.1. Competitors are required to notify the Secretary of the Event the Driver starting the race no later than 17:00 Saturday 8 April by submitting a Start Driver Nomination Form, as per Attachment D.
- 2.14.2. If the Start Driver Nomination Form is NOT received by the Secretary of the Event by the specified time as above, then the starting Driver will automatically default to the first nominated Driver as per the entry form Driver A.
- 2.14.3. If the nominated or default Driver does not start the race, a pit lane drive through penalty will be imposed.

### **3. BRIEFINGS, SCRUTINEERING, CHECKING**

#### **3.1. Briefings**

- 3.1.1. Team Managers Briefing:  
Details will be advised in the Further Supplementary Regulations.
- 3.1.2. Team Manager and Drivers Briefing:  
Details will be advised in the Further Supplementary Regulations.
- 3.1.3. Fire and Re-fuellers Briefing:
  - 3.1.3.1. Location: The large Grey Shed in the Camping Ground, immediately to the rear of Gate 2.
  - 3.1.3.2. Date and Time: To be advised in Further Supplementary Regulations
  - 3.1.3.3. Attendance is mandatory and failure to attend and sign the attendance sheet will result in a \$500 fine unless negated by the Stewards in exceptional circumstances.
  - 3.1.3.4. The 4 refuelling personnel who must attend are:
    - 3.1.3.4.1. Re-fueller Operator
    - 3.1.3.4.2. Fuel Rig Emergency Cut-Off Attendant (the dead man handle operator)
    - 3.1.3.4.3. Re-fueller Hose Assistant
    - 3.1.3.4.4. Fire Attendant (fire extinguisher operator)

#### **3.2. Scrutineering**

- 3.2.1. Scrutineering will take place at the Scrutineering Bay on Thursday 6 April from 08:00 to 18:00. A timetable will be issued in the Further Supplementary Regulations, any updates will be issued by email newsletter.
- 3.2.2. Each Automobile may be inspected, weighed, and have its fuel system capacity checked as a part of scrutineering.
- 3.2.3. All items listed in the Group 3E Series Production Car Regulations and Motorsport Australia Group 3E Recognition Document must be in place prior to scrutineering.
- 3.2.4. Each Team Manager must supply a completed and scanned Motorsport Australia Self -Scrutiny Statement of Vehicle Compliance to [administrator@bathurst6hour.com.au](mailto:administrator@bathurst6hour.com.au) by 24 March 2023.
- 3.2.5. Each Automobile must be presented for scrutineering:
  - 3.2.5.1. With the Motorsport Australia Group 3E Recognition Documents for that make and model as shown in the List of Eligible Automobiles in Attachment A;
  - 3.2.5.2. With fuel cell – The expiry date must be assessable to be checked;
  - 3.2.5.3. With Safety cage certificate/ registration in accordance with Technical Appendix – Schedule J of the Motorsport Australia Manual; and
  - 3.2.5.4. Without fuel.
- 3.2.6. Each Automobile will be issued with a scrutineering approval sticker once it has successfully completed scrutineering.
- 3.2.7. No Automobile may leave the Circuit after it has been issued with a scrutineering approval sticker without written permission of the TD. If such permission is given, the automobile must be presented to the TD, prior to its next track session, for further inspection.
- 3.2.8. Any Automobile failing to display the scrutineering approval sticker, or further inspection as per 3.2.7 may not be permitted to participate.

#### **3.3. Apparel Checking**

The apparel for each Driver and team member (including re-fuellers helmets, overalls, gloves etc) must be provided for inspection and approval.

Location: Drivers Briefing Room beside the Scrutineering Bay

Date and Time: Thursday 6 April between 08:00 and 18:00

### **3.4. Fire Extinguishers**

Each Competitor must provide 2 up to date, tagged and fully functional dry chemical powder fire extinguishers each of a minimum capacity of 4.5 kg (however 9 kg extinguishers are strongly recommended) for each of their Automobiles.

Note: 1 x 9 kg fire extinguisher is not an acceptable alternative.

Fire extinguishers will be checked in the pit lane garages on Friday 7 April between 09:00 and 17:00.

### **3.5. Overhead Fuel Rigs**

Overhead re-fuelling rigs will be checked as set up in the pit lane at a time to be advised in Further Supplementary Regulations.

## **4. PRACTICE, QUALIFYING, RACE, REPAIRS**

### **4.1. Start and End of Session Procedure**

- 4.1.1. When advised over the RMC, prior to the commencement of each Practice and Qualifying session, each Automobile must move to the pit lane in front of its garage on a 45 degree angle, nose out to the pit lane exit.
- 4.1.2. Once Pit Exit is open to commence a session all Automobiles are required to leave in Pit Lane Garage order, commencing with garage 1 unless advised otherwise on the RMC.
- 4.1.3. The procedure for the commencement of the race is detailed in 4.5.2
- 4.1.4. From the commencement of any qualifying session, an Automobile is prohibited to be moved back into the pit lane garage without the approval of the Chief Scrutineer or their nominee.
- 4.1.5. Unless directed by an Official, each Automobile, including those remaining in pit lane or given permission to move into their garage during qualifying, must proceed directly to the designated Parc Fermé area via the most direct route (or as directed by an Official) at the conclusion of each practice, qualifying and race, without returning to pit/garage/paddock areas and without interference from any third party (other than an Official).
- 4.1.6. At the conclusion of the Top 50% qualifying session the fastest 3 Automobiles may be required for Television interviews in which case Scrutineers will be assigned to each such Automobile.

### **4.2. Short Cutting the Track**

- 4.2.1. Practice and Qualifying:  
Any Automobile that short cuts the Track during practice or qualifying, including between Turn 11 to Turn 13 Drivers Left, will have that lap time deleted for each breach during each practice and qualifying session.
- 4.2.2. Racing:  
Any Automobile that short cuts the Circuit during the race, including between Turn 11 to Turn 13 Drivers Left, will be investigated for each breach and a penalty may be imposed by the Stewards at their discretion.

### **4.3. Qualifying**

- 4.3.1. Qualifying Format:
  - 4.3.1.1. There will be 2 x 20 minute qualifying sessions.
  - 4.3.1.2. The first session will be for the bottom 50% of Automobiles, based on their fastest practice lap time. Where there is an odd number of Automobiles, the first session will have the greater number of Automobiles.
  - 4.3.1.3. The second session will be for the top 50% of Automobiles, based on their fastest practice lap time.
  - 4.3.1.4. Each qualifying session may be extended by a maximum of 5 minutes at the discretion of the Clerk of the Course.
- 4.3.2. During the qualifying session there is NO requirement for each of the nominated Drivers to drive the Automobile. Unless approved otherwise by the Stewards, each Driver must set a lap time during practice or qualifying within 130% of the fastest lap time set during qualifying to be able to start the race.

### **4.4. Grid Determination**

Grid positions for the Bathurst 6 Hour Race will be based on the fastest lap times set during the 2 qualifying sessions. The Automobile with the fastest lap time will be placed on pole position and the remainder in order of their fastest lap time.

If two or more Automobiles record equal fastest lap times in the qualifying session, the first Automobile to record the lap time will take precedence as regards to grid positions.

#### **4.5. Start of Race**

##### **4.5.1. Start time of Race**

4.5.1.1. The formation lap for the race is scheduled to commence on Sunday 9 April at 11:15.

4.5.1.2. The start of the 6 hour race period will be when the green flag is displayed to commence the formation lap. This time will be used in calculations to determine:

4.5.1.2.1. the driving time as per Supplementary Regulation 2.13; and

4.5.1.2.2. the CPS window open / close period as per Supplementary Regulation 4.10

##### **4.5.2. Race start procedure**

The race will commence with a rolling start to be conducted in accordance with the procedure in the CRSR except for the following:

4.5.2.1. 35 minutes prior to the commencement of the formation lap: Each Automobile is required to be parked in pit lane in front of its garage on a 45-degree angle nose out, facing towards pit lane exit with the front right tyre placed where the concrete meets the bitumen. .

4.5.2.2. 30 minutes prior to the commencement of the formation lap: The pit lane exit will open for 1 reconnaissance lap to the grid with Automobiles to leave in pit lane garage order commencing with Garage 1 unless advised on the RMC. If an Automobile does not leave in pit lane order it must wait until the last Automobile has passed it in the fast lane.

4.5.2.3. 27 minutes prior to the commencement of the formation lap: A warning will sound to indicate 2 minutes prior to the closure of the pit Lane exit.

4.5.2.4. 25 minutes prior to the commencement of the formation lap: The pit lane exit will close. Any Automobile remaining in pit lane after it is closed will start the race from pit lane under the instructions of an official at pit exit.

4.5.2.5. At the end of the reconnaissance lap each Automobile must stop on its allocated grid position with its engine turned off.

Any further operational details of the start procedure will be detailed at the Driver Briefing.

#### **4.6. Major Repairs**

4.6.1. Any Automobile requiring extended servicing or repairs longer than 10 minutes must be moved into its pit lane garage. Once the Automobile is moved into the pit lane garage the number of persons permitted to service the Automobile is free.

4.6.2. If an Automobile requires repairs which cannot be conducted in the pit lane garage, subject to receiving the prior approval of the Chief Scrutineer, it is permitted for that Automobile to be removed from the pit lane garage to the TAFE repair centre for these repairs to be conducted. Once these repairs have been completed, the Automobile must be returned to its allocated pit lane garage before it re-joins the Circuit.

The removal and return of any Automobile in these circumstances must be conducted under the supervision of and subject to the instructions of the Chief Scrutineer or their nominee.

A 10km/h speed limit always applies in the paddock area.

4.6.3. With the exception of the above regulation 4.6.2, any repairs conducted on an Automobile outside of the pit lane must only be conducted by the Driver alone using only tools or parts transported in the Automobile.

Advice given to the Driver whether by electronic means or by voice is permitted.

4.6.4. With the exception of the above regulation 4.6.2, any replenishment of oil or water outside the pit lane is prohibited.

4.6.5. Any Automobile that has stopped on the Circuit and is returned to the Scrutineering Bay or TAFE repair centre by officials will have the following options:

4.6.5.1. Withdraw the Automobile from the Event, to be made in writing to the Secretary of the Event

4.6.5.2. Affect repairs in the pit lane garage and/or in the TAFE repair centre and then continue in the session and/or race.

4.6.6. Any Automobile that has left the pit lane for repairs must be inspected and approved by the Chief Scrutineer or their nominee before it re-joins the Track.

#### **4.7. Pit Lane & Pit Lane Garages**

4.7.1. The use of a pit boom is prohibited.

4.7.2. Fuel Storage:

4.7.2.1. For the duration of the Event, fuel must only be stored or transferred into any other storage vessel or an Automobile, at a temperature that is within 10 degrees Celsius of ambient temperature.

4.7.2.2. The maximum quantity of fuel that can be stored in each standard pit lane garage (refer 4.7.8) at any time is 200 litres, regardless if there is 1 or 2 Automobiles in a garage.

To clarify:

If 1 or 2 Automobiles are allocated to a 4m x 15m garage, only 1 x 200 litre drum of fuel may be stored in that garage at any time.

If 1 Automobile is allocated to an 8m x 15m garage, only 1 x 200 litre drum of fuel may be stored in that garage at any time.

4.7.2.3. The use of an overhead refuelling rig to store fuel is prohibited. An overhead refuelling rig must only contain fuel for the sole purpose of refuelling an Automobile.

4.7.3. Pit Lane Entry and Exit:

4.7.3.1. Except in the case of *Force Majeure* (accepted by the Stewards), any tyre of an Automobile exiting the pit lane must not cross any line painted on the Track at the pit exit for the purpose of separating an Automobile leaving the pit lane from those on the Track.

4.7.3.2. Except in the case of *Force Majeure* (accepted by the Stewards), any tyre of an Automobile entering the pit lane must not cross, in any direction any line painted on the Track at the pit entry for the purpose of separating Automobiles entering the pit lane from those on the Track.

4.7.3.3. Penalties as detailed below may be imposed.

4.7.3.3.1. During Practice or Qualifying:

4.7.3.3.1.1. First adjudged breach – a warning

4.7.3.3.1.2. Second and subsequent adjudged breaches – the penalty will be a loss of the fastest lap time in that session for each breach.

4.7.3.3.2. During Racing:

4.7.3.3.2.1. For each adjudged breach - a drive through penalty.

4.7.4. Pit Lane Speed limit

4.7.4.1. The Pit Lane speed limit is 40 km/h.

4.7.4.2. A penalty will be imposed in accordance with the CRSR for any breach of exceeding the pit lane speed limit.

4.7.5. The Prescribed Line referred to in these Regulations is the RED line painted in pit lane parallel to the garage fronts.

4.7.6. Competitors must not paint lines on any part of the pit lane.

4.7.7. Definition of a Standard Pit Lane Garage:

For this Event a Standard Pit Lane Garage is considered to be 4 metres x 15 metres, i.e., half of a full 8 metre x 15 metre garage.

4.7.8. Pit lane garage allocations will be at the sole discretion of the Bathurst 6 Hour Administrator, with Competitors allocated a garage on a shared basis with 2 Automobiles in each standard pit lane garage. When entries close there may be a limited number of standard pit lane garages available for sole use i.e., 1 Automobile per garage. An additional charge will be invoiced to competitors who request and receive a sole use standard garage.

Pit lane garage allocations may be changed by the Organiser or Bathurst 6 Hour Administrator at any time prior to Friday 7 April 2023, or thereafter in exceptional circumstances.

4.7.9. At all times during the Event the rear pit lane garage roller door facing the Paddock must remain FULLY open. Any pit walling must not block off the rear of the garage completely, and a minimum 3 metre continuous gap must be open.

- 4.7.10. After each session all equipment must be removed from the pit lane.
- 4.7.11. The area at the rear of the pit lane garages is an EMERGENCY CLEARWAY ACCESS ZONE and must always remain clear. Competitors are not permitted to store any equipment, have display vehicles or use this area for any purpose.
- 4.7.12. With exception to a free-standing timing beacon, no equipment is to be placed on the pit wall. If a free standing timing beacon is placed, it must not impede movement on the pit wall pathway.
- 4.7.13. Fire alarm detectors and/or sirens in pit lane garages are not to be tampered with. All tampering will be referred to Bathurst Regional Council for Civil charges to be laid under the Building and/or Fire codes, plus the cost of the repair of all the devices will be forwarded to the Competitor.
- 4.7.14. No person under the age of 16 years will be permitted in pit lane and/or pit lane garages.
  - 4.7.14.1. Teams will be given one warning for the first breach; after which
  - 4.7.14.2. If breaches are reported during practice and/or qualifying, the penalty will be the fastest lap time for that session deleted for each reported breach.
  - 4.7.14.3. If breaches are reported during the race, the penalty will be a drive through penalty for each reported breach.
  - 4.7.14.4. Each Pit Lane Marshal will be Judge of Fact.
- 4.7.15. The use of any type of gas heater within a pit lane garage is prohibited.
- 4.7.16. At all times each Competitor must comply with Dangerous Goods Act and Regulation – Storage and Handling of Hazardous Substances, plus the Work Health and Safety Act and Regulation for New South Wales.
- 4.7.17. Spark Generating Devices:  
The use of a spark generating device (grinder, welder etc.) within a pit lane garage is prohibited. If a repair is to be undertaken using a spark generating device, it must be taken to the TAFE repair centre.

#### **4.8. Pit Stop Procedures**

- 4.8.1. Car Controller:
  - 4.8.1.1. At all times whilst an Automobile is stationary in its pit bay it must remain under the control of a designated Car Controller who is solely responsible for holding the Automobile until the work is completed and releasing the Automobile safely back into the fast lane.
  - 4.8.1.2. The Car Controller must remain at the front of the Automobile in clear view of the Driver.
  - 4.8.1.3. The Car Controller is prohibited from performing any other function and will not count in any following regulation regarding the number of persons permitted to assist with a pit stop.
  - 4.8.1.4. For each pit stop, the Car Controller may be in a position in pit lane to assume control of the Automobile 1 lap before the Automobile crosses the control line at pit entry and must be behind the Prescribed Line before the Automobile crosses the line at pit lane exit.
  - 4.8.1.5. Each Car Controller must be attired as a re-fuelling person if re-fuelling is permitted during the session.
- 4.8.2. Driver Change:
  - 4.8.2.1. A Driver change may be conducted at any time during a pit stop.
  - 4.8.2.2. A Driver assistant may be used. If the Driver assistant is being used during the re-fuelling of the Automobile and the task is within 1 metre of the re-fuelling fittings, they must be attired as per a re-fueller.
  - 4.8.2.3. The incoming Driver, the exiting Driver and/or the nominated Driver assistant are permitted to perform the following duties;
    - 4.8.2.3.1. All actions associated with drink bottles.
    - 4.8.2.3.2. Disconnect and/or reconnect the Driver's window net.
    - 4.8.2.3.3. Unbuckle and/or re-buckle the Driver's seat belts.
    - 4.8.2.3.4. Adjust the steering column.
    - 4.8.2.3.5. Remove and/or reinstall the steering wheel.
    - 4.8.2.3.6. Disconnect and/or reconnect any helmet communication system plug/s.
    - 4.8.2.3.7. Disconnect and/or reconnect the Driver's drink bottle.
    - 4.8.2.3.8. Disconnect and/or reconnect the Driver's drink tube to helmet.

- 4.8.2.3.9. Disconnect and/or reconnect the leads to the Driver's cool suit.
- 4.8.2.3.10. Remove and/or reinstall a booster seat infill piece.
- 4.8.2.3.11. Any other task directly related to driver apparel that would assist a safe Driver change
- 4.8.2.4. The incoming Driver, the exiting Driver and/or the nominated Driver assistant are prohibited to refill the Driver's cool suit container. This must be completed by a general pit crew member.
- 4.8.2.5. If a Driver stays in the Automobile during the re-fuelling and/or the servicing of the Automobile, the use of a Driver assistant is prohibited. A general pit crew member must perform any task related to the Driver.
- 4.8.3. Pushing an Automobile:  
If an Automobile stops in pit lane before reaching, or passes its designated pit lane garage, the Automobile may be pushed to and/or back to its pit bay area by a maximum of any 4 members of its pit crew team.
- 4.8.4. Pit Stop Activities:
  - 4.8.4.1. A Pit Stop Procedure can be made up only of the following activities;
    - 4.8.4.1.1. Driver Change
    - 4.8.4.1.2. Refuelling the Automobile
    - 4.8.4.1.3. Servicing the Automobile
  - 4.8.4.2. Any refuelling of an Automobile must be completed prior to any servicing of the Automobile being conducted. At NO time are both the refuelling and servicing activities to be performed together.
  - 4.8.4.3. During a pit stop the engine may remain running or be switched off. However, when preparing to re-join the Track, the Automobile must start by its own means without any outside assistance.
  - 4.8.4.4. Equipment and personnel may only cross the Prescribed Line into pit lane after the Automobile has come to a complete stop within its pit bay. Once any equipment or personnel has crossed the Prescribed Line an activity will be deemed to have commenced.
  - 4.8.4.5. A wheel chock can be used exclusively to prevent the Automobile from rolling. If a wheel chock is being used it must be restrained. The preferred method of restraint is a rope that can be used to remove chock from behind the line.
  - 4.8.4.6. Other than the Car Controller, all personnel and equipment (other than a wheel chock and an overhead refuelling rig) must be behind the Prescribed Line before an activity will be deemed completed. Only then can a new activity commence, or the Car Controller can release the Automobile.
  - 4.8.4.7. During a pit stop all equipment related to an Automobile must remain within its pit bay or garage.
  - 4.8.4.8. Any Automobile driving over any equipment or personnel may receive a penalty as determined by the Stewards.
  - 4.8.4.9. The use of on-board jacking systems is prohibited. Each Automobile can only be lifted by the use of 1 commercially available standard trolley jack. Only 1 jack per Automobile is permitted across the Prescribed Line at any time.
  - 4.8.4.10. A maximum of 2 powered tools (brushless, hand or otherwise) used to loosen or re-tension the wheel nuts is permitted.
  - 4.8.4.11. During a pit stop, only 1 side or the front or the rear of the Automobile can be lifted at a time, and there must always be 2 tyres on the ground.
  - 4.8.4.12. Any person who assists during the pit stop by passing or moving tools and/or components from the pit lane garage over the Prescribed Line into pit lane, will be deemed as crossing the Prescribed Line into the pit lane.
  - 4.8.4.13. Any person receiving components or tools rolled or passed from pit lane over the Prescribed Line into the pit lane garage will not be deemed as crossing the Prescribed Line into the pit lane.
  - 4.8.4.14. Brake pad changes can be undertaken in conjunction with wheel changing operations.  
Note: A brake pad change is not mandatory during the race.

- 4.8.5. During the refuelling of an Automobile, 5 personnel are permitted to assist. The duties are restricted to the following and they are prohibited to participate in any other task during a refuelling activity:
- 4.8.5.1. Re-fueller (x1)  
The Re-fueller must only handle and operate the refuelling hose and nozzle for the duration of the Refuelling operation. This includes accessing any fuelling point if required (e.g., opening the boot).
  - 4.8.5.2. Fuel Rig Emergency Cut-Off Attendant (x1) – Dry-Break Refuelling  
The Fuel Rig Emergency Cut-Off Attendant must hold the valve of the re-fuelling rig open, only during the re-fuelling operations.
  - 4.8.5.3. Fire Attendant (x1)  
The Fire Attendant must be ready and located behind the Automobile (as shown in the diagram of 4.9.4) with a working fire extinguisher of not less than 4.5 kg.
  - 4.8.5.4. Re-fueller Hose Assistant Operator (x1)  
The Re-fueller Hose Assistant may hold the re-fuelling hose over the rear of the Automobile.
  - 4.8.5.5. General Pit Crew (x1)  
The General Pit Crew member is only permitted to cross the Prescribed Line to assist the Re-fueller with accessing the refuelling point (e.g., opening the boot) and/or if the Driver remains in the Automobile and requires assistance (e.g., drink bottle change, cool suit refill). If the general pit crew member is within 1 metre of the re-fuelling fittings, they must be attired as per a re-fueller.
- 4.8.6. During the servicing of an Automobile, 4 personnel are permitted to assist. The duties are:
- 4.8.6.1. Wheel/Tyre Changer (x 2)  
The Wheel/Tyre Changers must complete the wheel/tyre changing (including any work associated with it) if required and then carry out any other task associated with servicing the Automobile.
  - 4.8.6.2. General Pit Crew (x2)  
The General Pit Crew members are permitted to carry out any task associated with the servicing of the Automobile including assisting the Wheel/Tyre Changers.
  - 4.8.6.3. The following diagram is a guide to assist in the placement of personnel.

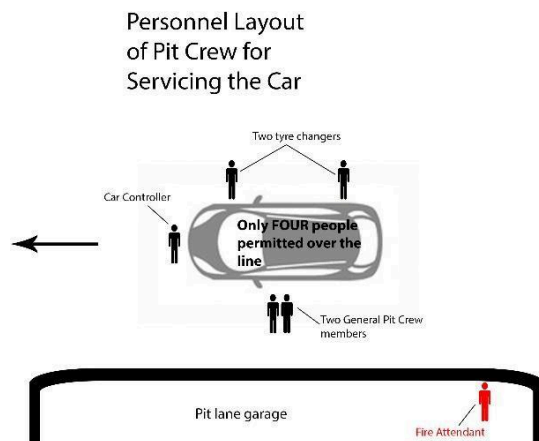

- 4.8.7. A single Team Data downloading person, the Nominated Driver Assistant, any TV broadcast crew members, and any Tyre company technicians are not counted in either Refuelling or Servicing crew.
- 4.9. Refuelling**
- 4.9.1. At all times during any practice session or race, re-fuelling of an Automobile must only be conducted in the pit lane in accordance with the Circuit Race Appendix – Refuelling in Pit Lane – Part 1 of the Motorsport Australia Manual.
  - 4.9.2. Refuelling is prohibited at any time during any qualifying session.

- 4.9.3. Each person attending an Automobile during a refuelling activity must be attired in compliance with the requirements of Circuit Race Appendix – Refuelling in Pit Lane – Part 1 of the Motorsport Australia Manual.
- 4.9.4. The following diagram is a guide to assist teams in the placement of personnel. Note that the re-fuelling rig must be located in the pit lane. The re-fuelling rig and all items attached to the fuel rig are not considered to be equipment that needs to be in the pit garage before and after a pit stop. The re-fuelling rig must not be moved once the race has started until the finish of the race without approval of the Chief Scrutineer or their nominee.

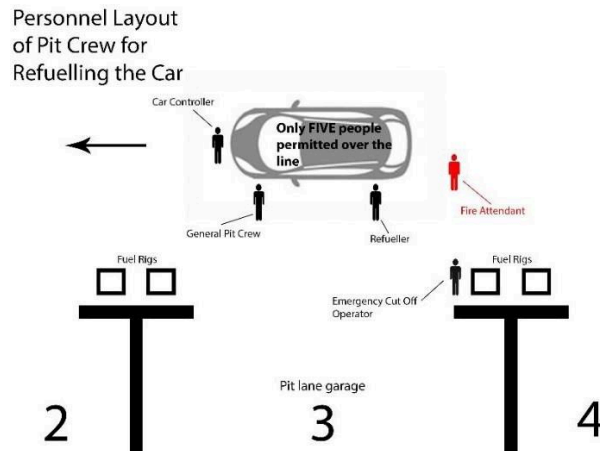

4.9.5. Overhead Refuelling Rig:

- 4.9.5.1. An overhead refuelling rig complying with Circuit Race Appendix – Refuelling in Pit Lane – Part 1 of the Motorsport Australia Manual must be used.
- 4.9.5.2. The overhead refuelling rig is only permitted to be in the pit lane and in use during nominated track sessions
- 4.9.5.3. When the overhead refuelling rig is not in use, it must be empty and located in the pit garage.
- 4.9.5.4. The overhead refuelling rig must not contain any fuel when it is being moved, nor when it is stored inside the pit garage.
- 4.9.5.5. The overhead refuelling rig must not be used to refuel an automobile outside of the nominated track sessions.
- 4.9.5.6. At all times when filling or emptying an overhead refuelling rig in the pit lane, all personnel must be fully attired in the apparel as per Circuit Race Appendix – Refuelling in Pit Lane – Part 1 of the Motorsport Australia Manual.
- 4.9.5.7. During ANY fuel transfer (Automobile to container, container to Automobile, container to container, container to tower, tower to container, tower to Automobile etc) each person involved in the transfer or within 1 metre of the re-fuelling fittings must be attired as per a re-fueller and a minimum of a 4.5 kg fire extinguisher must be present.
- 4.9.5.8. Each pit lane garage has 2 earthing points indicated by a green square plate marked “Equipotential Bond Point”. This is the ONLY earthing point for the overhead refuelling rig and each Team Managers is responsible for ensuring that their rig is connected appropriately.
- 4.9.5.9. Each overhead refuelling rig must be suitably restrained to the pit building structure to prevent it falling in the event of any accident in pit lane. The restraint of each overhead refuelling rig will be subject to the approval of the Chief Scrutineer. It is not permitted to drill the concrete floor and/or any part of the garage structure.
- 4.9.5.10. Each overhead refuelling rig must have a fuel flow restrictor fitted into the re-fuelling hose within 150 mm of the dry-break coupling through which all fuel being transferred to the Automobile must pass.  
The restrictor must be 75 mm long, be circular in section, and have a maximum internal diameter of 32 mm. The 32 mm restriction must be maintained for 3 mm. The

minimum internal diameter either side of the restriction is 44 mm, maintained for 36 mm. This restrictor must comply with the drawing as below:

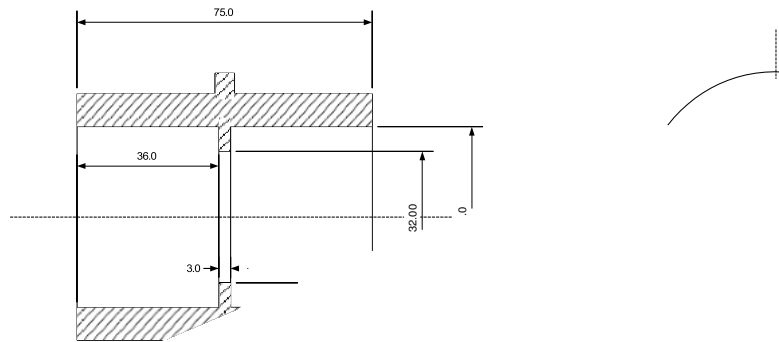

4.9.5.11. Any fuel spillage during filling the overhead fuel rig and/or re-fuelling the Automobile must be reported to the pit lane marshals for the spillage to be contained and neutralised.

4.9.5.11.1. The first recorded breach by a team will be a warning.

4.9.5.11.2. Any further breaches by the same team will be referred to the Stewards for a penalty.

#### 4.10. Compulsory Pit Stop (CPS)

4.10.1. Each Automobile must satisfactorily complete the minimum number of CPS during the race as required in the table below:

Class	Number	Class	Number
X	6	B2	3
A1	4	C	3
A2	4	D	3
B1	4	E	3

However, if an Automobile has not completed 75% of the race distance of the leader of their Class then the number of CPS will be prorated to match the race distance achieved.

4.10.2. The CPS procedure will be in accordance with the requirements of the CRSR, Supplementary Regulation 4.8 and the following.

4.10.3. Re-fuelling and/or servicing is permitted during a CPS.

4.10.4. A change of Driver is permitted during a CPS.

4.10.5. The CPS window will open 30 minutes after the start of the race, a board will be displayed at the finish line advising "Pit Window Open" and announced over the RMC.

4.10.6. The CPS window will close 330 minutes after the start of the race, a board will be displayed at the finish line advising "Pit Window Closed" and announced over the RMC.

4.10.7. The penalty for commencing a CPS when the CPS window is closed will be 5 laps deleted from the Automobile's total number of laps at the end of the race.

4.10.8. Failure to complete the required number of CPS will result in a penalty of 5 laps deleted from that Automobile's total number of laps at the end of the race.

4.10.9. The minimum CPS time is 1 minute and 30 seconds.

4.10.9.1. The minimum CPS time will be calculated from when an Automobile crosses the pit lane entry timing line, to when the Automobile crosses the pit lane exit timing line. The location of these timing lines will be confirmed at the Driver Briefing.

4.10.9.2. The penalty for going under the minimum CPS time will be a pit lane drive through penalty.

4.10.9.3. The Chief Timekeeper will be the sole Judge of Fact in regard to CPS time.

4.10.10. Once the minimum number of CPS have been completed by the Automobile, the minimum CPS time will not apply to any further pit stop/s either for refuelling or servicing the Automobile and the pit lane transit time is free.

4.10.11. Only 1 CPS is permitted during each Safety Car period.

**4.10.12. Discretionary Pit Stop (DPS):**

4.10.12.1. If a DPS is required (e.g., 1 flat tyre, mechanical issue, or loose body work) then the CPS requirements and any associated penalty do not apply.

4.10.12.2. No re-fuelling, Driver change, or servicing of the Automobile may be undertaken during a DPS.

4.10.12.3. If re-fuelling, Driver change, or servicing of the Automobile is undertaken then the pit stop will be considered a CPS and the CPS requirements, and any associated penalty will apply.

**4.11. Race Finish**

4.11.1. The chequered flag signalling the end of the race will be displayed to the lead Automobile 1 lap after 17:13.

4.11.2. If the leading Automobile is not running on the track at the time the race is scheduled to finish, the chequered flag will be shown to the next placed Automobile.

4.11.3. Finishers will be classified as per the CRSR.

4.11.4. The requirement of CRSR that to be classified as a finisher an Automobile must have completed at least 75% of the race distance completed by the leader does not apply.

4.11.5. There will be no cool down lap and each Automobile must exit the circuit via the gate on Mountain Straight after Turn 1.

4.11.6. Each Automobile which has completed the race, must proceed directly to the Parc Ferme area. Any breach of this regulation may result in disqualification from the race.

4.11.6.1. Some Automobiles may be required to proceed to the podium or to another location for media purposes. Any such Automobile will be under Parc Ferme conditions.

4.11.6.2. A team member must remain with each Automobile at all times while it is in Parc Ferme.

**4.12. Safety Car Intervention**

The Safety Car may be used to neutralise the race, and this will be as per the CRSR. All Safety Car activities will be advised to teams over the RMC.

**4.13. Stopping the Race:**

Any race stoppage or suspension will be in accordance with the requirements of the CRSR.

**4.14. Parc Ferme**

4.14.1. A single pit crew member per Automobile only is permitted into Parc Ferme to deliver and/or collect their Automobile after a session.

4.14.2. Each Automobile must remain in Parc Ferme until released by either the TD/ATD or Chief Scrutineer.

4.14.3. After the race, a representative from each team may approach their Automobile in Parc Ferme under supervision to remove all hired timing equipment and return to the timing representative present.

## 5. FUEL, TYRES

### 5.1. Fuel

- 5.1.1. Fuel must be 98 octane and exclusively supplied by the Organiser via RaceFuels.  
Email: [fuelorder@racefuels.com.au](mailto:fuelorder@racefuels.com.au)  
Phone: +61 (0)3 9706 5233
- 5.1.2. RaceFuels is the exclusive fuel supplier. All fuel used at the Event MUST be purchased from RaceFuels either in advance or during the Event and delivered at the Event.
- 5.1.3. Fuel will only be dispensed to each Competitor in sealed 200 litre drums. Each Competitor must have a hand pump to transfer the fuel to any overhead refuelling rig.
- 5.1.4. Competitors must contact RaceFuels and submit their Fuel order form by 1 April 2023. Failure to do this may result in no fuel being available for the Competitor.
- 5.1.5. Fuel prices will be confirmed by RaceFuels and further Fuel information is available at [racefuels.com.au](http://racefuels.com.au)

### 5.2. Tyres

- 5.2.1. Only MRF ZTR Control Tyres supplied by the Official Tyre Provider may be used during the Event.
- 5.2.2. A maximum of 24 new Control Tyres are permitted per Automobile for the duration of the Event.
  - 5.2.2.1. Each tyre will be allocated to a specific Automobile and must be exclusively used on that Automobile.
  - 5.2.2.2. Each tyre must be marked by the tyre supplier for exclusive use on each Automobile during all practice and qualifying sessions, and the race.
- 5.2.3. Tyres must be exclusively supplied by the Organiser via the Official Tyre Provider - Mentor Tyres:  
Vivek Ponnusamy  
Mentor Tyres  
Unit 106 – 52 Dow Street  
Port Melbourne, VIC 3207  
Phone: +61 (0)3 8395 0930  
Mobile: +61 (0) 424 246 611  
Email: [vivek@mentortyres.com.au](mailto:vivek@mentortyres.com.au)  
The Official Tyre Provider will be available at the circuit for the fitment of the tyres from:  
Wednesday 5 April 2023
- 5.2.4. A minimum of 8 Control Tyres must be ordered for each Automobile.
- 5.2.5. The minimum penalty for an Automobile that uses more than its allocated number of Control Tyres will be 5 laps (per tyre) deleted from that Automobile's total number of laps at the end of the race.
- 5.2.6. If an Automobile is fitted with a different size wheel rim on the front and rear axles, each tyre on the same axle must be of the same type.  
Note: the term 'Type' refers to the size, construction and compound of a given tyre.
- 5.2.7. The use of any tyre heating, heat retention devices or chemical treatments are prohibited.
- 5.2.8. With the exception of wear resulting from normal usage, all tyres must remain unmodified. Heat cycling new tyres is prohibited.
- 5.2.9. It is permitted to fit a device that solely monitors tyre conditions (e.g., pressure and temperature).
- 5.2.10. It is prohibited to use any device that automatically controls or changes the tyre pressure of each tyre fitted.
- 5.2.11. The tyre pressure may be increased to a maximum of 26 psi or 179.2 kPa during any ride height check.
- 5.2.12. The TD is the sole arbiter with regard to the interpretation and application of these Tyre Regulations and any decision made by the TD in this regard will not be the subject of any protest or appeal.

## 6. BALANCE OF PERFORMANCE

### 6.1. Balance of Performance (BoP)

- 6.1.1. Any Automobile may be subjected to a Balance of Performance (BoP) adjustment in the form of a variance to:
  - 6.1.1.1. Minimum Racing Weight
  - 6.1.1.2. Maximum allowable boost pressure of an Automobile with a forced induction engine
  - 6.1.1.3. The number of CPS
- 6.1.2. Any BoP will be advised by the TD and covered in a Technical Bulletin.
- 6.1.3. The Organiser reserves the right to apply BoP adjustment/s as follows:
  - 6.1.3.1. BoP adjustment/s of Boost pressure will only be applied when a Technical Bulletin changing the Boost pressure is issued, no later than 2 hours prior to the commencement of the Qualifying Sessions.
  - 6.1.3.2. Any other BoP adjustment/s may be applied at any time up to 2 hours prior to the commencement of the Bathurst 6 Hour Race.

### 6.2. Forced Induction Engines

- 6.2.1. Each Automobile which has a forced induction engine must be fitted with an MSE BM2012 Boost Monitor (Boost Monitor) manufactured after 2012 by:
  - Motor Sport Electronics
  - 22 Deep Pool Way
  - MT ANNAN, NSW 2567

Phone: +61 (02) 4648 0030  
Email: sales@msedata.com.au  
Mobile: +61 (0) 402 102 553  
Website: www.msedata.com.au
- 6.2.2. For each Automobile with a forced induction engine, the Maximum Manifold Boost Pressure (bar) is as specified in the List of Eligible Automobiles (refer Attachment A).
- 6.2.3. The TD/ATD has the right to check the output of the Boost Monitor at any time during the Event.
- 6.2.4. The TD/ATD can exchange an Automobile's Boost Monitor at any time.
- 6.2.5. The Boost Monitor must be installed in accordance with all instructions issued by Motor Sport Electronics and the TD and must remain fully operational to record the inlet manifold pressure of the Automobile for the duration of all practice sessions, qualifying sessions, and the race.
- 6.2.6. The Boost Monitor must be mounted in the engine bay of the Automobile and the hose to the inlet manifold must be visible and/or able to be felt along its entire length and the download port easily accessible. The connection hose is to be as short as practical and must connect to the Boost Monitor directly. The hose must not be crimped in any way by mounting, clamps, or cable ties. There must be no restrictions, perforations, cracks, or leaks of any kind in the hose.
- 6.2.7. If any Automobile's Boost Monitor is found by the TD/ATD to have recorded no data, corrupted data, incomplete data, uninterpretable data or manifold boost pressure (determined as described in Attachment C) over the maximum allowable for that Automobile during a qualifying session or the race, the TD will request the Stewards to impose a penalty of Disqualification of that Automobile from that session/race.
- 6.2.8. The TD will be the sole arbiter in regard to the interpretation of any data recorded by the Boost Monitor.
- 6.2.9. The TD/ATD may request access at any time to any other data being recorded by any device within the Automobile, for example a "MoTec Device".

## **7. ADDITIONAL INFORMATION**

### **7.1. Additional Flag Point**

- 7.1.1. The following flags will be displayed with an Automobile's competition number at Flag point 19.2, Drivers right at the start of Conrod Straight, in addition to display at the control line:
- 7.1.1.1. Black Flag (Automobile to enter pit lane)
  - 7.1.1.2. Black Flag with Orange Disc (Automobile to enter pit lane, mechanical)

### **7.2. Yellow Flashing Lights**

- 7.2.1. There are yellow flashing lights located at:

- 7.2.1.1. Turn 6 (Drivers Left)
- 7.2.1.2. Turn 8 (Drivers Right)
- 7.2.1.3. Turn 9 (Drivers Right)

These lights are a warning that there is a yellow, white, and/or yellow with red stripes flag sector ahead to Turn 10 (the Vista area).

- 7.2.2. There are yellow flashing lights located at:

- 7.2.2.1. Turn 10 (McPhillamy Park)
- 7.2.2.2. Turn 11 (Skyline)

These are a warning that there is a yellow, white, and/or yellow with red stripes flag sector ahead between Turn 10 (McPhillamy Park) and Turn 18 (Forest Elbow).

These yellow lights are for information purposes only and do not have any regulatory purpose.

### **7.3. Restricted Areas**

The Organiser may grant access to restricted areas. Access to these areas will be denied to any person not receiving permission and not wearing the appropriate pass. Misuse of any pass may result in disciplinary action against the offending party.

### **7.4. Waste Products**

The Organiser has provided an area for the disposal of waste oil and/or fluid products within the fuel compound. This is not for the disposal of used vehicle parts (i.e., oil filters etc). Other containers will be provided for these parts.

All Competitors must know that NO waste of any nature may be tipped into the storm water drains located within the Circuit or surrounding area.

All storm water drains lead directly to the Macquarie River and the Environmental Protection Agency (EPA) will be monitoring the situation in the lead up to and throughout the Event.

This includes the washing of any wheel rims within the vicinity of storm water drains.

Competitors are advised that the EPA are taking an extremely proactive approach to this matter, and you are put on notice that any infringement of this directive will result in action being taken by either the Organiser or the EPA or both.

The EPA can prosecute offenders with heavy penalties.

### **7.5. Press Conferences**

Details of any Press Conference will be advised by Bulletin at the Event.

### **7.6. Trophy Awards**

- 7.6.1. The following trophies will be provided by the Organiser:

- 7.6.1.1. Outright 1st, 2nd, 3rd
- 7.6.1.2. Each Class 1st, 2nd, 3rd

## 8. AUTOMOBILE MARKINGS

### 8.1. Compliance

- 8.1.1. The markings on each Automobile must comply with Technical Appendix - Schedule K of the Motorsport Australia Manual and any detail in these Supplementary Regulations.
- 8.1.2. The fitting of Event Sponsor decals in the positions shown in the Signage Diagram below is mandatory.
- 8.1.3. Decals will be checked prior to leaving the pit lane and any Automobile that does not comply with the Signage Diagram may be stopped in pit lane or black flagged and stopped from further participation in the Event until the Automobile complies.

### 8.2. Signage supplied by the Organiser

The Bathurst 6 Hour Administrator will supply the following for each Automobile during Event registration on Wednesday 5 and Thursday 6 April:

- 8.2.1. 1 set of Event Sponsor decals
- 8.2.2. White side number panels. These will be 380 mm wide x 260 mm high and are to be placed on each front side door, 10 mm to 20 mm back from the leading edge of the front door.
- 8.2.3. Competition numbers. These will be 180 mm high x 300 mm wide and in the type face "Maiandra GD Bold Italic".
- 8.2.4. Automobile Class door letters. These will be 100 mm high in "Maiandra GD bold italic" and must be placed on the bottom right-hand side of the number panel.
- 8.2.5. Automobile Class and competition number front and rear windscreen decals. Numbers will be 150 mm high in Dayglo Yellow, "Helvetica Bold". Class decals will be 80 mm high. These must be placed 25 mm from the side of the windscreen and 25 mm below the bottom of the windscreen strip opposite side to the Driver as per the diagram.
- 8.2.6. Two Motorsport Australia decals which must be placed next to each side panel.

### 8.3. Areas to be left vacant

The following areas must be left vacant for use by the Organiser:

- 8.3.1. The front and rear windscreen strip (220 mm from bottom of strip to top of windscreen). Other than the Organisers signage, no signage can be on the front or rear windscreen.
- 8.3.2. A section 380 mm wide x 120 mm high above each side number panel.
- 8.3.3. The front and rear number plate areas unless otherwise agreed with the Organiser. Decals supplied by the Organiser will be 380 mm x 100 mm and the Competitor must ensure that they fit their Automobile.  
Any other signage is prohibited on the front or rear number plate areas.
- 8.3.4. Two 330 mm x 90 mm areas on the front bumper
- 8.3.5. Two 330 mm x 90 mm areas on the rear bumper

### 8.4. Signage to be supplied by the Competitor

- 8.4.1 Driver name decals are to be supplied by the Competitor. Each Driver's surname must be placed on each rear side window in white letters, font type "Helvetica bold". The size can be determined by the Competitor.

### 8.5. Signage available for purchase

The following signage will be available for purchase from the Secretary of the Event, Office Tower 3, Level 1:

- 8.5.1. Battery Triangle, Electrical Cut off Switch Triangle, Tow Triangle.

### 8.6. Official Sign Supplier

Sign Event is the official sign-writing supplier for the Event:

Mark Weissel

Phone: +61 (0) 7 5529 2650

Email: [mark@signevent.com.au](mailto:mark@signevent.com.au)

**8.7. Signage Diagram**



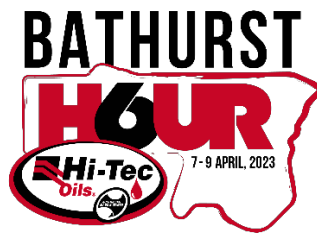

## Attachment A

### CLASS STRUCTURE & AUTOMOBILE ELIGIBILITY LIST

The following automobile makes/models are eligible to compete in the respective Classes of the Hi-Tec Oils Bathurst 6 Hour:

#### Notes for Classes X, A, B, C, D, E:

1. Only makes/models that are detailed on this list of Eligible Automobiles and contained in these regulations are eligible to compete.
2. For a make/model to be considered for inclusion into this list of Eligible Automobiles for the Hi-Tec Oils Bathurst 6 Hour, it must meet the eligibility requirements of the Motorsport Group 3E - Series Production Car Regulations.
3. At all times Organiser reserves the right to accept or reject any application for the inclusion of any make/model onto the list of Eligible Automobiles for the Hi-Tec Oils Bathurst 6 Hour (for any reason). Before investing in the purchase and/or modification or preparation of any make/model which is not detailed on the list of Eligible Automobiles, the Competitor should contact the Organiser regarding its eligibility.
4. Individual classification of any make/model is subject to change by the Event organiser at any time.
5. Any variations sought to a specific model of automobile must be approved, in writing, by Motorsport Australia prior to being permitted to compete in the Event.
6. Automobiles in all classes may be subject to additional BoP measures imposed at the Event.

CLASS X - Ultimate Performance					
Make	Model	Designation	Recognition Document No	Maximum Manifold Boost Pressure (bar)	Minimum Racing Weight (kg)
<b>Alfa Romeo</b>	Giulia Quadrifoglio	952		TBA	1543
<b>Audi</b>	RS3	8V		TBA	1534
<b>AUDI</b>	TT RS Plus	FV MY18		TBA	1448
<b>BMW</b>	M2 Coupe	F87 LCI Competition	3-21-013	TBA	1496
<b>BMW</b>	M3	F80, F80 LCI Competition	3-18-011	1.79	1478

CLASS X - Ultimate Performance					
<b>BMW</b>	M4	F82	3-17-002	1.79	1494
<b>BMW</b>	M3	G80 Manual		TBA	1602
<b>BMW</b>	M4	G82 Manual		TBA	1598
<b>Holden</b>	HSV GTS	VF MY14	3-14-006	0.92	1750

CLASS A1 - Extreme Performance Forced Induction					
Make	Model	Designation	Recognition Document No	Maximum Manifold Pressure (bar)	Minimum Racing Weight (kg)
<b>Audi</b>	TTS	FV3	3-21-004	1.3	1430
<b>Audi</b>	TT RS Plus	8J	3-21-002	1.25	1448
<b>BMW</b>	1M	E82	3-12-003	0.95	1462
<b>BMW</b>	M135i	F20	3-14-004	1.95 (absolute)	1398
<b>BMW</b>	M140i	F20		TBA	1418
<b>BMW</b>	M235i	F22		TBA	1423
<b>BMW</b>	M240i	F22	3-22-001	TBA	1438
<b>Ford</b>	FPV F6	FG	3-10-009	0.91	1696
<b>Ford</b>	FPV GT-F	FG2	3-17-008	0.75	1748
<b>Ford</b>	XR6 Turbo Sprint	FGX		1.2	1651
<b>Ford</b>	XR8	FGX		TBA	1736
<b>Ford</b>	FPV F6 TYPOON	BF2		TBA	1672
<b>Ford</b>	FPV GT-P	FG	3-09-008	TBA	1754
<b>Ford</b>	FPV GT R-Spec	FG2	3-14-007	TBA	1710
<b>Ford</b>	Focus RS	LZ	3-17-007	1.85	1521
<b>Mercedes-Benz</b>	AMG A45(2016)	W176 MY16	3-17-004	1.8	1480
<b>Mercedes-Benz</b>	AMG A45	W176 MY13	3-16-004	1.8	1480
<b>Mitsubishi</b>	Lancer Evo X	RS	3-09-030	1.4	1486
<b>Mitsubishi</b>	Lancer Evo IX	RS, GSR	3-09-028	1.21	1450

CLASS A1 - Extreme Performance Forced Induction					
<b>Mitsubishi</b>	Lancer Evo VIII	RS	3-09-029	1.21	1466
<b>Mitsubishi</b>	Lancer Evo VII	RS		1.21	
<b>Mitsubishi</b>	Lancer Evo VI	6.5 TME		1.21	1330
<b>Mitsubishi</b>	Lancer Evo V	RS		1.02	1192
<b>Subaru</b>	Impreza WRX Sti	GK MY15	3-17-003	1.31	1470
<b>Subaru</b>	Impreza WRX Sti	G-3 MY10	3-09-037	1.31	1395
<b>Toyota</b>	Yaris GR	XPA1G		TBA	1290
<b>Volkswagen</b>	Golf R	Series 7.5	3-19-008	1.3	1448
<b>Volkswagen</b>	Golf R	Series 7		TBA	1435

CLASS A2 - Extreme Performance Naturally Aspirated					
Make	Model	Designation	Recognition Document No	Maximum Manifold Pressure (bar)	Minimum Racing Weight (kg)
<b>Audi</b>	RS4	B8		N/A	1718
<b>Audi</b>	S4	B7 V8		N/A	1579
<b>Audi</b>	S5	8T V8		N/A	1568
<b>Ford</b>	Mustang GT	FM	3-19-007	N/A	1632
<b>Ford</b>	Mustang GT	FN (Man)	3-20-005	N/A	1661
<b>Ford</b>	Mustang GT	FN (Auto)	3.20-005	N/A	1674
<b>Ford</b>	Mustang Mach 1	FN	3-21-011	N/A	1681
<b>Ford</b>	Mustang Bullitt	FN	3-20-007	N/A	1661
<b>Holden</b>	HSV GTS	VY/VY2	3-09-018	N/A	1581
<b>Holden</b>	HSV GTS Coupe	V2		N/A	1565
<b>Holden</b>	HSV GTO Coupe, GTS Coupe	VZ	3-09-017NN	N/A	1560
<b>Holden</b>	HSV R8 Clubsport	VZ	3-18-008	N/A	1591
<b>Holden</b>	HSV R8 Clubsport	VF	3-18-021	N/A	1644
<b>Holden</b>	HSV R8 Clubsport	VE/VE2	3-09-018NN	N/A	1707
<b>Holden</b>	HSV GTS	VE/VE2	3-11-007	N/A	1707

CLASS A2 - Extreme Performance Naturally Aspirated					
Holden	HSV GTS	VX	3-19-019	N/A	1590
Holden	SS, SSV Redline (6.2)	VF II	3-18-022	N/A	1675
HSV Chevrolet	Camaro	2SS		N/A	1599
Lexus	RC RCF	USC10R	3-19-011	N/A	1741
Mercedes-Benz	C63	W204	3-18-009	N/A	1663

CLASS B1 - High Performance Forced Induction					
Make	Model	Designation	Recognition Document No	Maximum Manifold Pressure (bar)	Minimum Racing Weight (kg)
AUDI	S1	8X		TBA	1360
AUDI	TT	FV3		TBA	1390
BMW	135i	E82	3-09-042	0.80	1425
BMW	335i	E90, E92	3-09-004	0.80	1480
Ford	XR6 Turbo	BF, BF2	3-09-006	0.64	1646
Ford	Focus RS	LV		TBA	1455
Honda	Civic Type R	FK8	3-21-001	1.60	1389
Hyundai	I30N	PDE	3-18-015	2.205 (absolute)	1408
Hyundai	I30N	2021		TBA	1440
Kia	Stinger 330 GT	CK		TBA	1668
Mini	Cooper S JCW	F56		TBA	1180
Peugeot	308 Gti 270	T9	3-21-102	TBA	1178
Renault	Megane RS 275 Trophy R	X95		TBA	1247
Subaru	Impreza WRX Sti	GD	3-21-006	1.0	1437
Subaru	Impreza WRX	G-3 MY09	3-09-036	TBA	1370
Volkswagen	Golf R	Gen 6	3-19-001	1.20	1472
Volkswagen	Golf GTi TCR	Gen 7.5	3-21-007	1.30	1387

CLASS B2 - High Performance Naturally Aspirated					
Make	Model	Designation	Recognition Document No	Maximum Manifold Pressure (bar)	Minimum Racing Weight (kg)
BMW	M3	E46	3-18-007	N/A	1452
BMW	M3	E90, E92	3-18-016	N/A	1517
Ford	XR8	BF, BF2	3-9-007	N/A	1646
Ford	XR8	FG	3-9-009NN	N/A	
Ford	FPV GT, GT-P	BA, BA2	3-09-005	N/A	1687
Ford	FPV GT, GT-P	BF, BF2		N/A	1700
Holden	Commodore SS	VX		N/A	1542
Holden	HSV R8 Clubsport	VX		N/A	
Holden	Commodore SS, SV	VY		N/A	1565
Holden	Commodore SS, SV, SS-Z	VZ	3-09-014	N/A	1565
Holden	Commodore SSV-Redline	VE	3-19-002	N/A	1618
Holden	Commodore SSV-Z	VE	3-19-004	N/A	1659
Holden	Commodore SS, SSV Redline, SSV CL	VF (6.0)	3-17-006	N/A	1626

CLASS C - Performance					
Make	Model	Designation	Recognition Document No	Maximum Manifold Pressure (bar)	Minimum Racing Weight (kg)
Alfa Romeo	Guilietta QV 1.8	Series 2	3-17-001	1.50	1299
Audi	TT	3.2 Quattro MY05		N/A	1410
BMW	130i	E87	3-09-003	N/A	1355
BMW	M3	E36 3.2L	3-19-015	N/A	1448
BMW	M3	E36 3.0L	3-19-016	N/A	1448
Holden	Astra HSV VXR	AH	3-11-004	1.2	1333

CLASS C - Performance					
Holden	Astra HSV VXR	PJ	3-20-001	1.50	1489
Mazda	3 MPS	BL	3-11-002	1.10	1420
Mazda	3 MPS	BK 3A, 3B	3-09-025	1.10	1403
Mazda	6 MPS	6A	3-12-010	1.10	1534
Mini	Cooper S JCW	R56	3-13-014	TBA	1120
Mini	Cooper S	F56		TBA	1135
Renault	Megane RS 265	X95	3-14-005	1.55	1374
Renault	Megane RS 265 Trophy R	X95	3-21-003	1.55	1247
Renault	Clio RS200 Sport	X98	3-19-013	2.0	1176
Suzuki	Swift Turbo	AZ	3-22-003	TBA	945
Volkswagen	Scirocco R	Gen 3	3-19-005	1.20	1351
Volkswagen	Polo GTi	AW	3-22-002	1.35	1303
Volkswagen	Golf GTi	Gen 7	3-19-020	1.2	1337
Volkswagen	Golf GTi	Gen 7 My15 Manual	3-21-008	1.2	1313
Volkswagen	Golf GTi Performance Pack	Gen 7	3-21-005	1.2	1377

CLASS D - Production					
Make	Model	Designation	Recognition Document No	Maximum Manifold Pressure (bar)	Minimum Racing Weight (kg)
Alfa Romeo	Mito Sport	Series 1		TBA	1142
BMW	125i	E82		N/A	1375
Ford	Fiesta ST	WZ	3-18-020	1.5	1172
Honda	Integra Type R	DC2	3-18-023	N/A	1087
Honda	Integra Type R	DC5	3-09-015	N/A	1160
Honda	Integra Type S	DC5	3-09-016	N/A	1230
Kia	Proceed GT	JD	3-17-005	1.2	1280
Mazda	RX-8 GT	FE Series 2	3-11-003	N/A	1377

CLASS D - Production					
<b>Mazda</b>	RX-8 Series 1	RX8A	3-19-010	N/A	1299
<b>Mazda</b>	6 Diesel	GJ	3-13-011	2.70 (absolute)	1471
<b>Mini</b>	Cooper S	R56	3-21-009	TBA	1120
<b>Mini</b>	Cooper S	R53	3-21-010	TBA	1110
<b>Nissan</b>	Pulsar SSS	N14	3-18-024	N/A	1141
<b>Nissan</b>	Pulsar	N15	3-18-010	N/A	1102
<b>Renault</b>	Clio Sport 197	X85	3-10-012	N/A	1221
<b>Subaru</b>	BRZ	Z-1	3-19-022	N/A	1255
<b>Subaru</b>	BRZ	ZD8		N/A	1246
<b>Toyota</b>	Camry	XV20		N/A	1345
<b>Toyota</b>	Celica SX	ZR	3-09-038	N/A	1085
<b>Toyota</b>	Corolla Sportivo	ZZE123R	3-10-010	N/A	1238
<b>Toyota</b>	86 GT	ZN SER	3-19-009	N/A	1179
<b>Toyota</b>	86 GTS	ZN SER	3-13-009	N/A	1198
<b>Toyota</b>	86 GT	ZN 2018	3-20-002	N/A	1218
<b>Toyota</b>	86 GTS	ZN 2018	3-20-003	N/A	1215
<b>Toyota</b>	GR 86	ZN8		N/A	1246
<b>Volkswagen</b>	Golf Gti	GEN 5	3-19-023	1.0	1340
<b>Volkswagen</b>	Golf Gti	GEN 6		TBA	1360
<b>Volkswagen</b>	Polo Gti	9N		1.00	1190

CLASS E - Compact					
Make	Model	Designation	Recognition Document No	Maximum Manifold Pressure (bar)	Minimum Racing Weight (kg)
<b>BMW</b>	325i	E46		NA	1400
<b>BMW</b>	325Ti	E46		NA	1380
<b>Hyundai</b>	Getz	TB	3-17-009	N/A	1077
<b>Mazda</b>	2	DJ, DE		N/A	980
<b>Mazda</b>	3	3C		N/A	1240

<b>CLASS E - Compact</b>					
<b>Mazda</b>	3 SP23	BK S1, S2	3-19-012	N/A	1227
<b>Mazda</b>	3 SP25	BL S1, S2	3-18-018	N/A	1305
<b>Proton</b>	Satria GTi	BS	3-11-001	N/A	1163
<b>Suzuki</b>	Swift Sport	FZ	3-19-006	N/A	1030
<b>Suzuki</b>	Swift Sport	EZ RS416	3-18-017	N/A	1067
<b>Toyota</b>	Echo	10 SER	3-09-039	N/A	884
<b>Toyota</b>	Yaris YRX	NCP91R	3-10-011	N/A	1094

## Attachment B

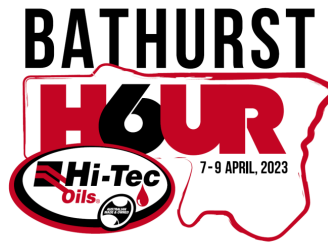

### 2023 Bathurst 6 Hour Teams Radio Form

Please advise the radio frequency that your team (to car) will be using during the 2023 Bathurst 6 Hour event. All frequencies must be registered and approved for use by yourself with the ACMA.

Team Car Number: \_\_\_\_\_

Competitor: \_\_\_\_\_

Frequency: \_\_\_\_\_

Sub-Tone or, \_\_\_\_\_

RAN or, \_\_\_\_\_

Colour and Slot: \_\_\_\_\_

Please complete this form, scan, and send to:

[administrator@bathurst6hour.com.au](mailto:administrator@bathurst6hour.com.au) by 10 March 2023.

# Attachment C

## Interpretation of the MSE Boost Monitor data

The Technical Director will apply the following method to determine if the boost manifold pressure data logged by the Boost Monitor fitted to an Automobile exceeds the Maximum Manifold Boost Pressure permitted for that Automobile (refer Attachment A):

1. Data will be averaged over a 5 second period.
2. The 5 second period will commence from a post throttle application spike.
3. The average pressure determined by the Boost Monitor software over this 5 second period will be used as the recorded manifold boost pressure.
4. A tolerance of +0.03 bar will be applied to the Maximum Manifold Boost Pressure permitted to allow for any interpretation variance of the average figure.

Example:

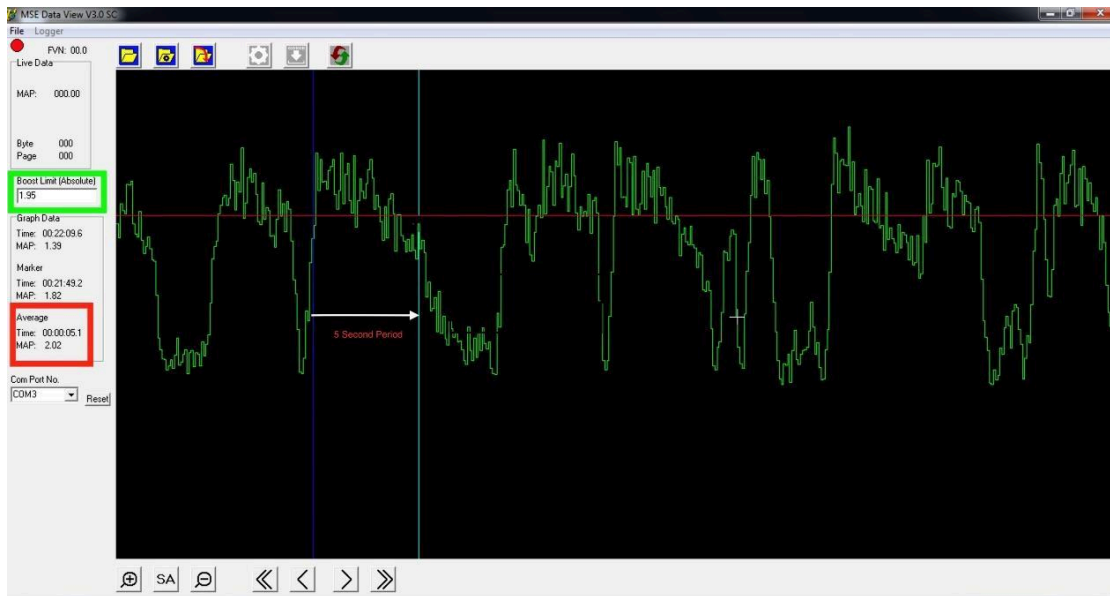

The above shows an average over 5 seconds of MAP: 2.02. The Boost Limit (Absolute) is 1.95.

With the addition of the interpretation tolerance of +0.03 BAR this reading would be determined as being over the permitted boost limit.

## Attachment D



# Hi-Tec Oils Bathurst 6 Hour April 7 - 9 2023

## Starting Driver Nomination Form

*This form must be returned the Secretary of the Event by 1700hrs, Saturday 8<sup>th</sup> April 2023*

<b>Car Number:</b>	
<b>Class:</b>	
<b>Starting Driver Name:</b>	

**Name of Team Manager:** \_\_\_\_\_

**Signature of Team Manager:** \_\_\_\_\_